

FEATURES

- Multi-level PIR signal processing*
- Digital Microwave signal processing
- DRO microwave technology for low current and reliable operation
- MOV transient / static protection
- High RF immunity with SMD construction
- Exceptional white light immunity
- Microprocessor low voltage protection
- Tamper switch
- Form 'A' alarm contacts

SPECIFICATIONS

ELECTRICAL

Operating Voltage	9.5 to 14.5 VDC
Ripple Tolerance	3 VP-P at 12 VDC
Stand-by Current	30 mA at 12 VDC
Alarm Current	30 mA at 12 VDC
Alarm Contacts	Form 'A' (standard) Form 'C' (optional)
Tamper Contact	Optional
Contact Ratings	100 mA at 24 VDC
Alarm Contact Series Resistance	10Ω 0.25W

OPERATION

Coverage (max. length x max. width)	30' x 40' (9m x 12m)
Alarm Duration	2 seconds
Walk Speed	0.5 ft/s to 10 ft/s (0.15m/s to 3.0m/s)
Nominal Mounting Height	7.5' (2.3m)
Jumper	Alarm LED on/off

IMMUNITY

RF Immunity	30 V/m over range 0.01 to 1200 MHz
Transients at Terminals	2.4 kV at 1.2 joules
Static Discharge Immunity	25 kV
White Light	20 000 Lux at the detector
Operating Temperature	32° to 122° F (0° to 50° C)
Humidity	5% to 95% RH non-condensing

DESCRIPTION

The Force 2 211R is a Short Range Dual Detector employing both Microwave (MW) and Passive Infrared (PIR) motion sensors. The sensors are combined through a microprocessor to provide "intelligent" motion detection designed to eliminate "single detector" false alarms.

Significant new technical features such as Multi-Level PIR signal processing, a high reliability DRO microwave sensor and digital MW signal analysis combine for a new level of detection sensitivity, stability and false alarm immunity.

The PIR and MW systems are each designed as independent, high quality motion detectors. When combined, the result is a detector with unmatched performance.

The detector indicates an alarm when both sensors detect motion within 10 seconds of each other. The first sensor, either the PIR or MW, which detects motion will start the 10 second confirmation period during which the other sensor must also detect motion. If the first sensor's detection is not confirmed within 10 seconds, the unit disregards the alarm.

PIR / MW BEAM PATTERNS

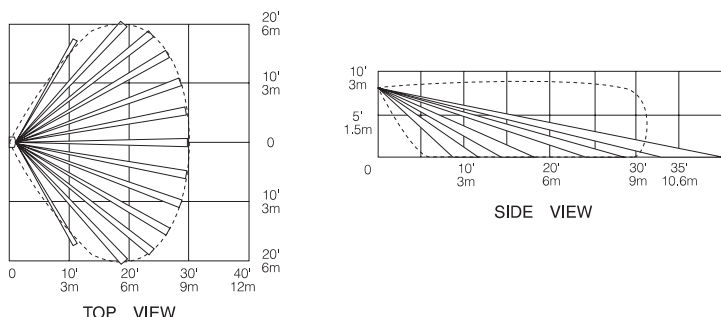

LOCATING THE DETECTOR

Mount the detector in a dry indoor location which will allow the intruder to walk perpendicular to the beam, and allows the beam pattern to adequately cover the area being protected. Survey the mounting location and the area being protected for the following potential problems.

MOUNTING HEIGHT

The FORCE 2 is designed to provide optimum coverage when mounted between 2.1m (7') to 2.4m (8') from the floor. If the unit is mounted above 2.4m (8'), the PIR will have a slightly longer range, but the "dead" zone directly below the unit will be increased. If the unit is mounted below 2.1m (7') the PIR section will have a shorter range and the "dead" zone directly below the detector will be decreased.

REFLECTIVE/METALLIC SURFACES

Do not aim the detector at reflective surfaces or metallic surfaces that could vibrate. Reflective surfaces could distort the PIR coverage pattern; vibrating metallic surfaces or rotating fans could be seen as motion by the MW sensor. Metallic surfaces close to the unit may reduce MW sensitivity.

AIR FLOW

The FORCE 2 is protected against air flow and airborne contamination. However, do not locate the detector where it will be subject to direct high air flow such as fans, hot air vents or open windows.

CONTAMINATION

Do not locate the detector near a source of oil or water vapour, such as a steaming kettle or cooking area in a kitchen.

SUNSHINE

The FORCE 2 is resistant to white light but direct sunlight is a high energy source. Do not locate the detector where it will receive direct sunlight, particularly in the morning or evening when the sun is low and may shine in through a window.

TEMPERATURE CHANGES

Do not aim the detector at objects that change temperature rapidly, such as heaters or ovens.

OBSTRUCTIONS

Do not limit the desired area of protection with large objects such as plants or filing cabinets.

PETS

Do not aim the detector where pets may trigger either the Microwave or PIR motion sensors. If both sensors are tripped, an alarm will result.

DISASSEMBLING THE DETECTOR

To open the detector, pull on the front of the detector while pressing on the release at the bottom of the detector with a small screwdriver.

To remove the circuit board and sensor assembly from the detector case, press gently on the top of the MW detector until the circuit board unlocks and slides towards the bottom of the detector.

To replace the circuit board and sensor assembly, place the circuit board assembly into the detector's back so that the white plastic frame fits into the two slots in the detector's back. Press gently on the bottom of the MW detector assembly to slide the circuit board towards the top of the detector. The circuit board assembly will snap firmly into place.

NOTE: To avoid damage to the detector, do not press against any of the components on the circuit board when removing and replacing the board.

With the circuit board removed, use a small screwdriver to punch out the wiring and mounting knockouts located in the detector's back. Feed the wiring through the wiring knockout and secure the detector to the wall.

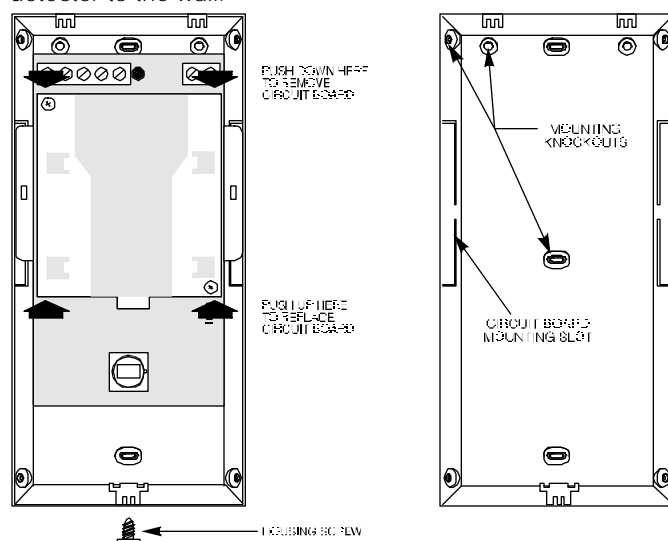

DM-C AND DM-W DETECTOR MOUNTING BRACKETS

Use the optional DM-W Wall Mount and DM-C Ceiling Mount brackets to solve difficult placement problems. The DM-W and DM-C mount to either the wall or ceiling and allow for full vertical and horizontal positioning of the motion detector - the detector can be tilted up or down and rotated through 90° to obtain the best position for optimal coverage. The New Force 2 has been designed to be fully compatible with the DM-W and DM-C brackets. Contact your DSC distributor for more information.

DM-C
Ceiling Mounting Bracket

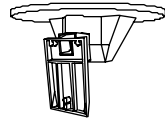

DM-W
Wall Mounting Bracket

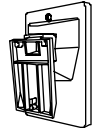

IMPORTANT NOTE: Maximum detection coverage occurs when the FORCE 2 is mounted at the height specified in the mounting instructions and the mounting surface is vertical. If this cannot be achieved with a mounting bracket, then detector coverage may be less than specified.

WIRING

Once the detector is mounted in the desired location, connect the wiring as shown below. Note that various models have the following optional features.

NOTE: Contacts are shown in the non-alarm state with power applied to the detector.

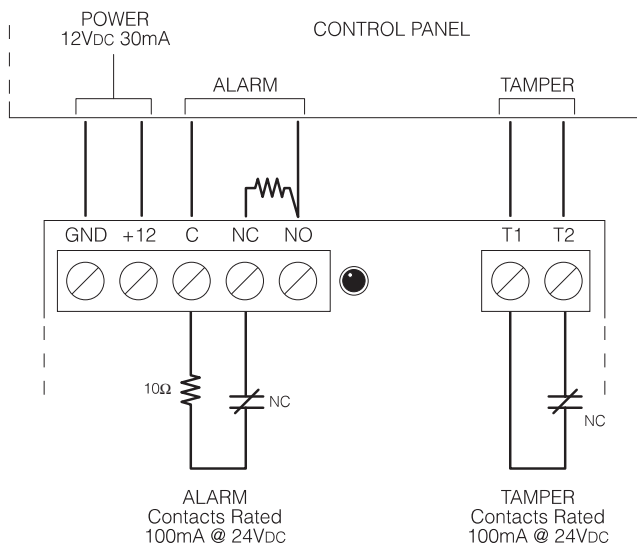

POWER UP

Upon application of power, the alarm indicator will be illuminated for 60 seconds to indicate the unit is warming up. During this period, the alarm relay is held in its normal non-alarm state. After the 60 second warm-up period, the alarm indicator will go out and the unit will respond to motion in the protected area.

ALARM INDICATOR ON/OFF JUMPER J1

With Jumper J1 OFF, the alarm indicator will turn on each time the unit goes into alarm. With J1 ON, the alarm indicator is disabled.

WALK TESTING

It is imperative that the unit be thoroughly walk tested after mounting to ensure that coverage extends over the desired area.

Once coverage has been confirmed, Jumper J1 may be set to the ON position to disable the alarm LED indicator.

NOTE: Make sure to secure the front cover with the supplied housing screw.

IMPORTANT NOTE: Upon installation, the unit should be thoroughly tested to verify proper operation. The end user should be instructed on how to perform walk tests, and should perform a walk test at least once per year.

COMPONENT LOCATIONS

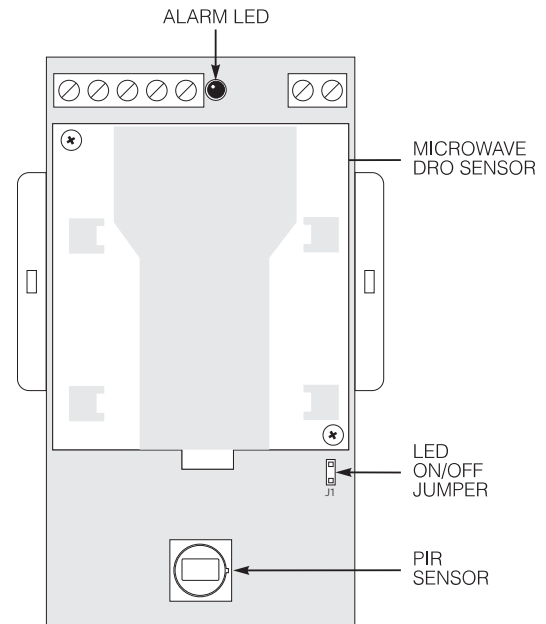

PIR LENS

The PIR lens is mounted with the textured side facing in (smooth side facing out). Note that the long lens elements are at the top when the lens is properly positioned. Ensure the lens is properly seated, and that the lens holder is securely snapped into place.

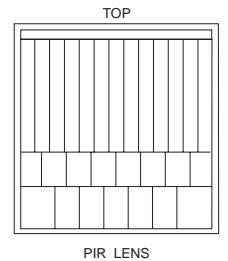

LIMITED WARRANTY

Digital Security Controls Ltd. warrants that for a period of five years from the date of purchase, the product shall be free of defects in materials and workmanship under normal use and that in fulfillment of any breach of such warranty, Digital Security Controls Ltd. shall, at its option, repair or replace the defective equipment upon return of the equipment to its repair depot. This warranty applies only to defects in parts and workmanship and not to damage incurred in shipping or handling, or damage due to causes beyond the control of Digital Security Controls Ltd. such as lightning, excessive voltage, mechanical shock, water damage, or damage arising out of abuse, alteration or improper application of the equipment.

The foregoing warranty shall apply only to the original buyer, and is and shall be in lieu of any and all other warranties, whether expressed or implied and of all other obligations or liabilities on the part of Digital Security Controls Ltd. Digital Security Controls Ltd. neither assumes, nor authorizes any other person purporting to act on its behalf to modify or to change this warranty, nor to assume for it any other warranty or liability concerning this product.

In no event shall Digital Security Controls Ltd. be liable for any direct, indirect or consequential damages, loss of anticipated profits, loss of time or any other losses incurred by the buyer in connection with the purchase, installation or operation or failure of this product.

WARNING: Digital Security Controls Ltd. recommends that the entire system be completely tested on a regular basis. However, despite frequent testing, and due to, but not limited to, criminal tampering or electrical disruption, it is possible for this product to fail to perform as expected.

IMPORTANT INFORMATION

CHANGES OR MODIFICATIONS NOT EXPRESSLY APPROVED BY DIGITAL SECURITY CONTROLS LTD. COULD VOID THE USER'S AUTHORITY TO OPERATE THIS EQUIPMENT.

THIS DEVICE COMPLIES WITH PART 15 OF THE FCC RULES. OPERATION IS SUBJECT TO THE FOLLOWING TWO CONDITIONS: (1) THIS DEVICE MAY NOT CAUSE HARMFUL INTERFERENCE, AND (2) THIS DEVICE MUST ACCEPT ANY INTERFERENCE RECEIVED, INCLUDING INTERFERENCE THAT MAY CAUSE UNDESIRE OPERATION.



Digital Security Controls Ltd.
1645 Flint Road
Downsview, Ontario
Canada M3J 2J6
Phone: (416) 665-8460
Fax: (416) 665-7498

THE NEW **FORCE 2** is a trademark of Digital Security Controls Ltd.



FEATURES

- Multi-level PIR signal processing*
- Digital Microwave signal processing
- DRO microwave technology for low current and reliable operation
- MOV transient / static protection
- High RF immunity with SMD construction
- Exceptional white light immunity
- Microprocessor low voltage protection
- Tamper switch
- Form 'A' alarm contacts

SPECIFICATIONS

ELECTRICAL

Operating Voltage	9.5 to 14.5 VDC
Ripple Tolerance	3 VP-P at 12 VDC
Stand-by Current	30 mA at 12 VDC
Alarm Current	30 mA at 12 VDC
Alarm Contacts	Form 'A' (standard) Form 'C' (optional)
Tamper Contact	Optional
Contact Ratings	100 mA at 24 VDC
Alarm Contact Series Resistance	10Ω 0.25W

OPERATION

Coverage (max. length x max. width)	30' x 40' (9m x 12m)
Alarm Duration	2 seconds
Walk Speed	0.5 ft/s to 10 ft/s (0.15m/s to 3.0m/s)
Nominal Mounting Height	7.5' (2.3m)
Jumper	Alarm LED on/off

IMMUNITY

RF Immunity	30 V/m over range 0.01 to 1200 MHz
Transients at Terminals	2.4 kV at 1.2 joules
Static Discharge Immunity	25 kV
White Light	20 000 Lux at the detector
Operating Temperature	32° to 122° F (0° to 50° C)
Humidity	5% to 95% RH non-condensing

DESCRIPTION

The Force 2 211R is a Short Range Dual Detector employing both Microwave (MW) and Passive Infrared (PIR) motion sensors. The sensors are combined through a microprocessor to provide "intelligent" motion detection designed to eliminate "single detector" false alarms.

Significant new technical features such as Multi-Level PIR signal processing, a high reliability DRO microwave sensor and digital MW signal analysis combine for a new level of detection sensitivity, stability and false alarm immunity.

The PIR and MW systems are each designed as independent, high quality motion detectors. When combined, the result is a detector with unmatched performance.

The detector indicates an alarm when both sensors detect motion within 10 seconds of each other. The first sensor, either the PIR or MW, which detects motion will start the 10 second confirmation period during which the other sensor must also detect motion. If the first sensor's detection is not confirmed within 10 seconds, the unit disregards the alarm.

PIR / MW BEAM PATTERNS

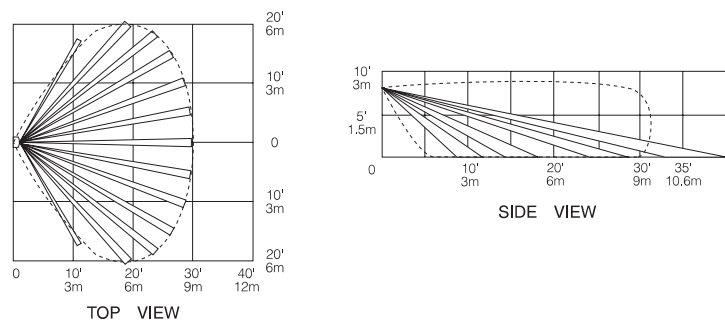

LOCATING THE DETECTOR

Mount the detector in a dry indoor location which will allow the intruder to walk perpendicular to the beam, and allows the beam pattern to adequately cover the area being protected. Survey the mounting location and the area being protected for the following potential problems.

MOUNTING HEIGHT

The FORCE 2 is designed to provide optimum coverage when mounted between 2.1m (7') to 2.4m (8') from the floor. If the unit is mounted above 2.4m (8'), the PIR will have a slightly longer range, but the "dead" zone directly below the unit will be increased. If the unit is mounted below 2.1m (7') the PIR section will have a shorter range and the "dead" zone directly below the detector will be decreased.

REFLECTIVE/METALLIC SURFACES

Do not aim the detector at reflective surfaces or metallic surfaces that could vibrate. Reflective surfaces could distort the PIR coverage pattern; vibrating metallic surfaces or rotating fans could be seen as motion by the MW sensor. Metallic surfaces close to the unit may reduce MW sensitivity.

AIR FLOW

The FORCE 2 is protected against air flow and airborne contamination. However, do not locate the detector where it will be subject to direct high air flow such as fans, hot air vents or open windows.

CONTAMINATION

Do not locate the detector near a source of oil or water vapour, such as a steaming kettle or cooking area in a kitchen.

SUNSHINE

The FORCE 2 is resistant to white light but direct sunlight is a high energy source. Do not locate the detector where it will receive direct sunlight, particularly in the morning or evening when the sun is low and may shine in through a window.

TEMPERATURE CHANGES

Do not aim the detector at objects that change temperature rapidly, such as heaters or ovens.

OBSTRUCTIONS

Do not limit the desired area of protection with large objects such as plants or filing cabinets.

PETS

Do not aim the detector where pets may trigger either the Microwave or PIR motion sensors. If both sensors are tripped, an alarm will result.

DISASSEMBLING THE DETECTOR

To open the detector, pull on the front of the detector while pressing on the release at the bottom of the detector with a small screwdriver.

To remove the circuit board and sensor assembly from the detector case, press gently on the top of the MW detector until the circuit board unlocks and slides towards the bottom of the detector.

To replace the circuit board and sensor assembly, place the circuit board assembly into the detector's back so that the white plastic frame fits into the two slots in the detector's back. Press gently on the bottom of the MW detector assembly to slide the circuit board towards the top of the detector. The circuit board assembly will snap firmly into place.

NOTE: To avoid damage to the detector, do not press against any of the components on the circuit board when removing and replacing the board.

With the circuit board removed, use a small screwdriver to punch out the wiring and mounting knockouts located in the detector's back. Feed the wiring through the wiring knockout and secure the detector to the wall.

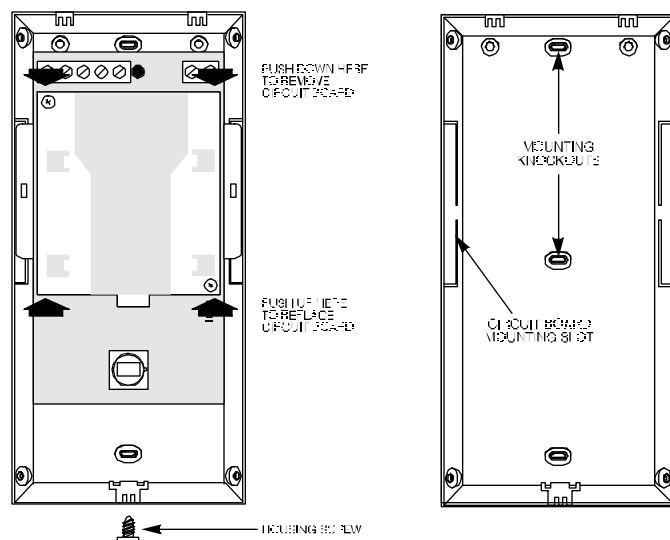

DM-C AND DM-W DETECTOR MOUNTING BRACKETS

Use the optional DM-W Wall Mount and DM-C Ceiling Mount brackets to solve difficult placement problems. The DM-W and DM-C mount to either the wall or ceiling and allow for full vertical and horizontal positioning of the motion detector - the detector can be tilted up or down and rotated through 90° to obtain the best position for optimal coverage. The New Force 2 has been designed to be fully compatible with the DM-W and DM-C brackets. Contact your DSC distributor for more information.

DM-C
Ceiling Mounting Bracket

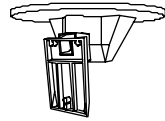

DM-W
Wall Mounting Bracket

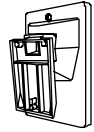

IMPORTANT NOTE: Maximum detection coverage occurs when the FORCE 2 is mounted at the height specified in the mounting instructions and the mounting surface is vertical. If this cannot be achieved with a mounting bracket, then detector coverage may be less than specified.

WIRING

Once the detector is mounted in the desired location, connect the wiring as shown below. Note that various models have the following optional features.

NOTE: Contacts are shown in the non-alarm state with power applied to the detector.

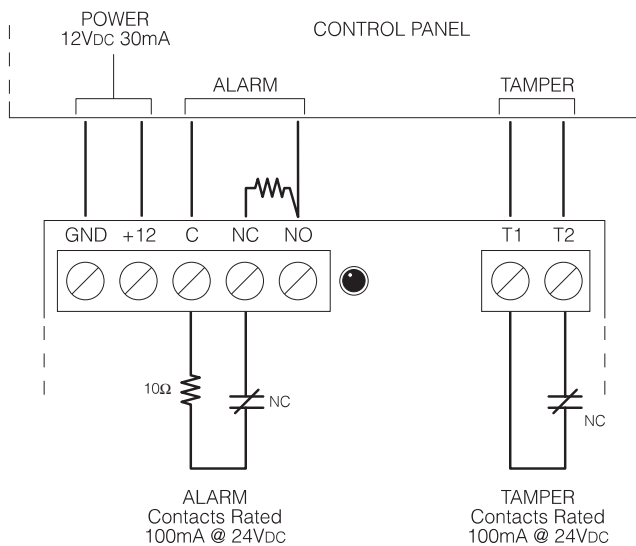

POWER UP

Upon application of power, the alarm indicator will be illuminated for 60 seconds to indicate the unit is warming up. During this period, the alarm relay is held in its normal non-alarm state. After the 60 second warm-up period, the alarm indicator will go out and the unit will respond to motion in the protected area.

ALARM INDICATOR ON/OFF JUMPER J1

With Jumper J1 OFF, the alarm indicator will turn on each time the unit goes into alarm. With J1 ON, the alarm indicator is disabled.

WALK TESTING

It is imperative that the unit be thoroughly walk tested after mounting to ensure that coverage extends over the desired area.

Once coverage has been confirmed, Jumper J1 may be set to the ON position to disable the alarm LED indicator.

NOTE: Make sure to secure the front cover with the supplied housing screw.

IMPORTANT NOTE: Upon installation, the unit should be thoroughly tested to verify proper operation. The end user should be instructed on how to perform walk tests, and should perform a walk test at least once per year.

COMPONENT LOCATIONS

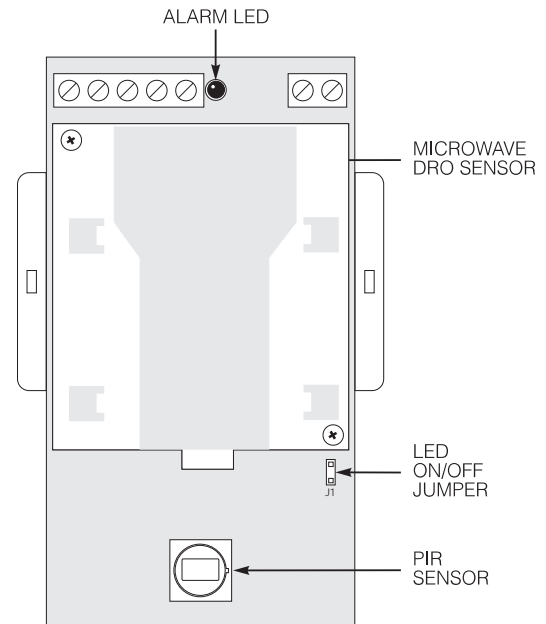

PIR LENS

The PIR lens is mounted with the textured side facing in (smooth side facing out). Note that the long lens elements are at the top when the lens is properly positioned. Ensure the lens is properly seated, and that the lens holder is securely snapped into place.

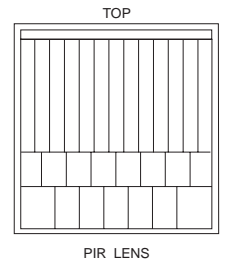

LIMITED WARRANTY

Digital Security Controls Ltd. warrants that for a period of five years from the date of purchase, the product shall be free of defects in materials and workmanship under normal use and that in fulfillment of any breach of such warranty, Digital Security Controls Ltd. shall, at its option, repair or replace the defective equipment upon return of the equipment to its repair depot. This warranty applies only to defects in parts and workmanship and not to damage incurred in shipping or handling, or damage due to causes beyond the control of Digital Security Controls Ltd. such as lightning, excessive voltage, mechanical shock, water damage, or damage arising out of abuse, alteration or improper application of the equipment.

The foregoing warranty shall apply only to the original buyer, and is and shall be in lieu of any and all other warranties, whether expressed or implied and of all other obligations or liabilities on the part of Digital Security Controls Ltd. Digital Security Controls Ltd. neither assumes, nor authorizes any other person purporting to act on its behalf to modify or to change this warranty, nor to assume for it any other warranty or liability concerning this product.

In no event shall Digital Security Controls Ltd. be liable for any direct, indirect or consequential damages, loss of anticipated profits, loss of time or any other losses incurred by the buyer in connection with the purchase, installation or operation or failure of this product.

WARNING: Digital Security Controls Ltd. recommends that the entire system be completely tested on a regular basis. However, despite frequent testing, and due to, but not limited to, criminal tampering or electrical disruption, it is possible for this product to fail to perform as expected.

IMPORTANT INFORMATION

CHANGES OR MODIFICATIONS NOT EXPRESSLY APPROVED BY DIGITAL SECURITY CONTROLS LTD. COULD VOID THE USER'S AUTHORITY TO OPERATE THIS EQUIPMENT.

THIS DEVICE COMPLIES WITH PART 15 OF THE FCC RULES. OPERATION IS SUBJECT TO THE FOLLOWING TWO CONDITIONS: (1) THIS DEVICE MAY NOT CAUSE HARMFUL INTERFERENCE, AND (2) THIS DEVICE MUST ACCEPT ANY INTERFERENCE RECEIVED, INCLUDING INTERFERENCE THAT MAY CAUSE UNDESIRE OPERATION.



Digital Security Controls Ltd.
1645 Flint Road
Downsview, Ontario
Canada M3J 2J6
Phone: (416) 665-8460
Fax: (416) 665-7498

THE NEW **FORCE 2** is a trademark of Digital Security Controls Ltd.

